

HDP 170 High Pressure Pump Series

Design criteria

Hammelmann high pressure pumps are built to operate at the continuous maximum duty stated in the performance parameters. Just compare the crankshaft speed, average plunger speed, plunger diameter and power rating.

High pressure pump

Weight: approx. 525 kg

Energy efficient →

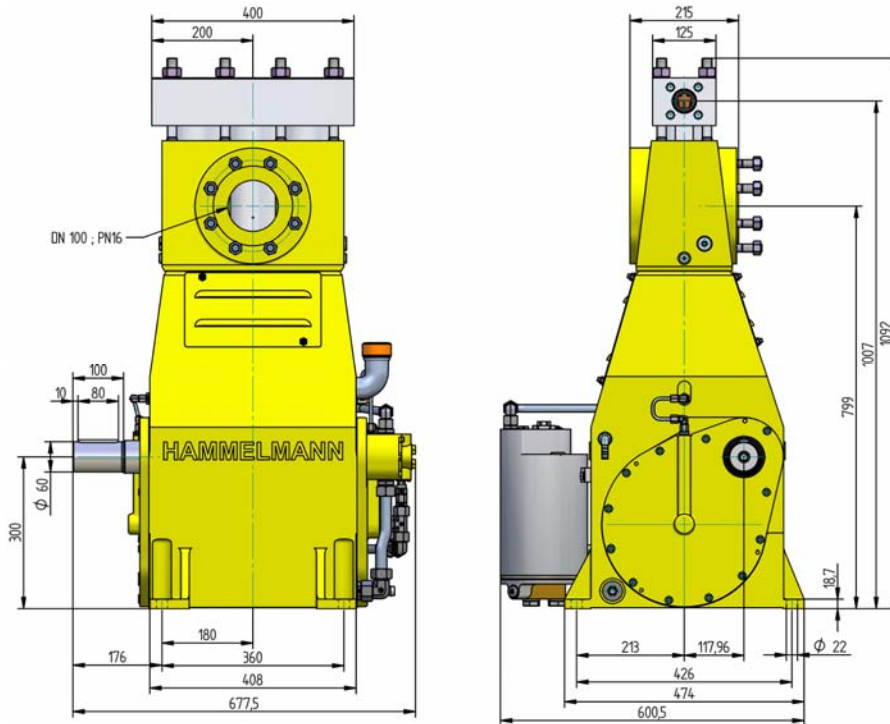

Features

- Power ratings up to 170 kW
- Vertical 3 cylinder design
- Wide variety of complementary ancillaries

Quality and reliability

- Stainless steel pump head free of alternating stress
- Bellows form hermetic seal between the suction chamber and crank section
- Choice of application specific seal assemblies
- Solid ceramic or tungsten carbide plungers
- Choice of bronze (standard) or stainless steel suction chamber
- Crank section calculation by 'Finite element method' ensures long working life under continuous load
- Integral speed reduction gear
- Pressurised oil lubrication system with oil cooler/filter

Stationary unit with electric motor

Length: 2048 mm
Width: 885 mm
Height: 1350 mm
Weight: approx. 2000 kg at 160 kW

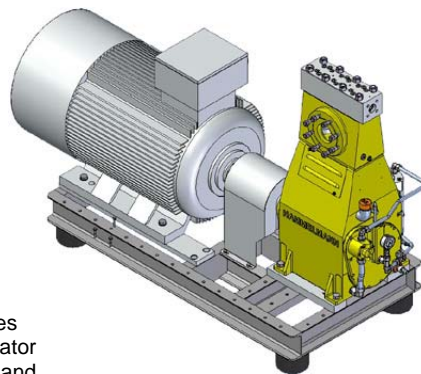

Main dimensions without accessories such as suction line, pressure regulator etc. Detailed dimensional drawings and weights available on request.

Stationary unit with diesel motor

Length: 2405 mm
Width: 1540 mm
Height: 1995 mm
Weight: approx. 3500 kg at 186 kW with full fuel tank

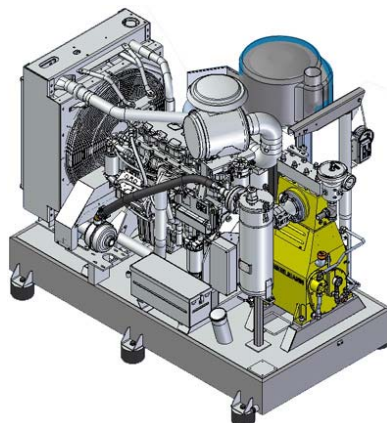

HAMMELMANN®

HDP 170 series, technical data

Performance parameters (Standard design)

Note: Actual flow rates for water as pumped medium (volumetric efficiency has already been taken into account).

HDP	Q [l/min]	Required power rating [kW]						D	r.p.m.	
		75	90	110	132	160	170		n 1	n 2
		Operating pressure [bar]								
174	20 / 18*	2050*	2450*	3000*				17,5	1500	385
	24 / 22*	1700	2050*	2500*	3000*	3200*	1500/1800		465	
	28 / 26*	1400	1700	2100*	2500*	3000*	3200*		1800/2150	555
174	26 / 24*	1550	1850	2300*	2600*		20	1500	385	
	31 / 28*	1300	1550	1900	2300*	2600*		1500/1800	465	
	37 / 34*	1100	1300	1600	1900	2300*		2600*	1800/2150	555
		*Ultra high pressure		3200 bar only for stationary units						
173	40	1000	1200	1450	1650		25	1500	385	
	48		1000	1200	1450	1650		1500/1800	465	
	57			1000	1200	1450		1650	1800/2150	555
172	57	690	830	1000	1150		30	1500	385	
	69	580	690	850	1000	1150		1500/1800	465	
	82	480	580	710	850	1000		1150	1800/2150	555
	79	510	610	750	850		35	1500	385	
	94	420	510	620	750	850		1500/1800	465	
	113	350	430	520	630	760		850	1800/2150	555
	104	390	470	570	650		40	1500	385	
	124	320	390	480	570	650		1500/1800	465	
	149	270	320	400	480	580		620	1800/2150	555
	133	310	370	450	510		45	1500	385	
	159	260	310	380	450	510		1500/1800	465	
	190	210	260	310	380	460		490	1800/2150	555
	165	250	300	370	420		50	1500	385	
	198	210	250	300	360	420		1500/1800	465	
	237	170	210	250	300	370		400	1800/2150	555
	200	200	250	300	340		55	1500	385	
	239	170	200	250	300	340		1500/1800	465	
	285	140	170	210	250	300		330	1800/2150	555
	236	170	210	250	290		60	1500	385	
	282	140	170	210	250	290		1500/1800	465	
	338	120	140	170	210	260		270	1800/2150	555
	321	120	150	180	210		70	1500	385	
	384	100	120	150	180	210		1500/1800	465	
	460	90	100	130	150	190		200	1800/2150	555

- Rod force: 82 kN
- Stroke: 75 mm
- Mean piston speed at n₂
 - 385 r.p.m. = 0,97 m/sec
 - 465 r.p.m. = 1,16 m/sec
 - 555 r.p.m. = 1,39 m/sec

Typical high pressure pump units



- Mobile unit with electric motor



- Road going trailer or stationary units with sound damping cover



- 10 or 20 foot sound damped container versions

HDP	Seal **	Sealing system
174	Dynamic	Tungsten carbide plunger & bushing
	Packing	Special ceramic plunger *** / packing
173	Dynamic	Ceramic plunger / bronze bushing
	Packing	Ceramic plunger / packing
172	Dynamic	Ceramic plunger / bronze bushing
	Packing	Ceramik plunger / packing

D = Piston/Plunger dia. [mm]
n1 = Motor/Engine r.p.m.
n2 = Crankshaft r.p.m.

Conversion table
Rating 1 kW = 1.34 HP
Op. pressure 1 bar = 14.5 psi
Flow rate 1 l = 0.264 US gallon
1 l = 0.22 Imp. gallon

** The dynamic high pressure sealing extends the advantages of the labyrinth design with further increased efficiency.

*** Special ceramic plungers up to max. 2600 bar.



Hammelmann plunger pumps convert 93 to 98 % of the shaft power to hydraulic energy.

Hammelmann Maschinenfabrik GmbH
Postfach 3309 • D-59282 Oelde Telefon (+49) 25 22 76-0
Zum Sundern 13-21 • Germany Telefax (+49) 25 22 76-444
eMail: mail@hammelmann.de • Internet: www.hammelmann.com

HAMMELMANN®