

# HDP 40 High Pressure Pump Series

## Design criteria

Hammelmann high pressure pumps are built to operate at the continuous maximum duty stated in the performance parameters. Just compare the crankshaft speed, average plunger speed, plunger diameter and power rating.

### High pressure pump

Weight: approx. 200 kg

Energy efficient →

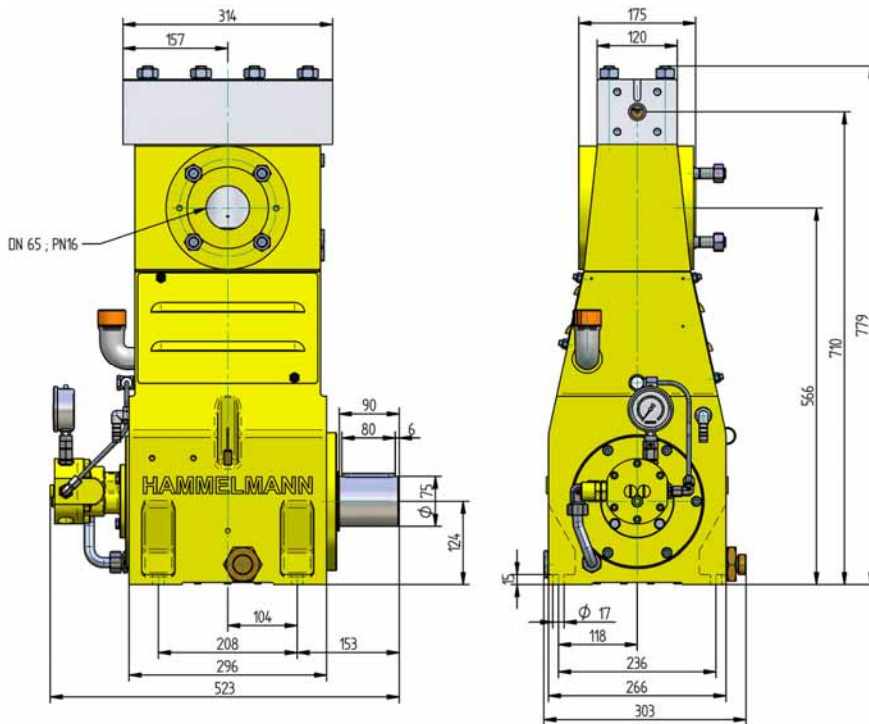

### Features

- Power ratings up to 37 kW
- Vertical 3 cylinder design
- Wide variety of complementary ancillaries

### Quality and reliability

- Stainless steel pump head free of alternating stress
- Bellows form hermetic seal between the suction chamber and crank section
- Choice of application specific seal assemblies
- Solid ceramic or tungsten carbide plungers
- Choice of bronze (standard) or stainless steel suction chamber
- Crank section calculation by 'Finite element method' ensures long working life under continuous load
- Pressurised oil lubrication system

### Stationary unit with electric motor

Length: 1100 mm  
Width: 833 mm  
Height: 1100 mm  
Weight: approx. 730 kg at 30 kW

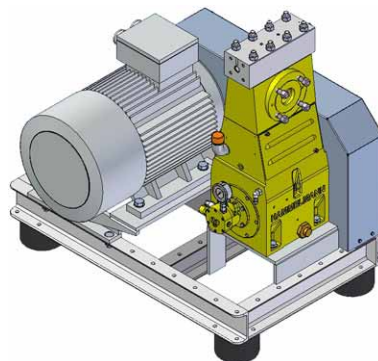

Main dimensions without accessories such as suction line, pressure regulator etc. All shown as right side drive. Detailed dimensional drawings and weights available on request.

# HDP 40 series, technical data

## Performance parameters (Standardausführung)

**Note: Actual flow rates for water as pumped medium (volumetric efficiency has already been taken into account).**

HDP	Q [l/min]	Required power rating [kW]					D	r. p. m.	
		15	18,5	22	30	37		n 1	n 2
		Operating pressure [bar]							
44	5,7 / 5,5*	1350	1650	2050*	2800*	3000*	12	1500 / 1800 / 2150	625
	6,9 / 6,5*	1100	1400	1650	2350*	2900*			750
	8,2 / 7,8*	930	1150	1350	1850	2400*			900
	8,5	860	1060	1250	1700	2200*	15		625
	11	720	880	1050	1450	1750			750
	13	600	740	880	1200	1500			900
	12,5	630	780	930	1250	1550	17,5		625
	15	530	650	770	1050	1300			750
	18	440	540	650	880	1100			900
	*Ultra high pressure								
43	16,5	480	600	710	970	1200	20	1500/1800/ 2150	625
	20	400	500	590	810	1000			750
42	20	400	490	590	800	980	22	1500 / 1800 / 2150	625
	24	330	410	490	670	820			750
	24	330	410	490	670	830	24		625
	29	280	340	410	560	690			750
	28	280	350	420	570	710	26		625
	34	240	290	350	480	590			750
	38	210	260	310	430	530	30		625
	45	180	220	260	360	440			750
	52	150	190	230	310	390	35		625
	62	130	160	190	260	320			750
	68	120	150	170	240	300	40		625
	82	100	125	145	200	250			750
	86	95	115	140	190	230	45		625
	103	80	95	115	160	190			750
	107	75	95	110	150	190	50		625
	128	65	80	95	130	160			750
129	60	80	90	125	160	55	625		
155	50	65	75	105	130		750		

Conversion table  
 Rating 1 kW = 1.34 HP  
 Op. pressure 1 bar = 14.5 psi  
 Flow rate 1 l = 0.264 US gallon  
 1 l = 0.22 Imp. gallon

D = Piston/Plunger dia. [mm]  
 n1 = Motor/Engine r.p.m.  
 n2 = Crankshaft r.p.m.

HDP	Seal **	Sealing system
44	Dynamic	Tungsten carbide plunger & bushing
	Packing	Special ceramic plunger *** / packing
43	Dynamic	Ceramic plunger / bronze bushing
	Packing	Ceramic plunger / packing
42	Dynamic	Ceramic plunger / bronze bushing
	Packing	Ceramik plunger / packing

\*\* The dynamic high pressure sealing extends the advantages of the labyrinth design with further increased efficiency.  
 \*\*\* Special ceramic plungers up to max. 2500 bar.



Hammelmann plunger pumps convert 93 to 98 % of the shaft power to hydraulic energy.

Hammelmann Maschinenfabrik GmbH  
 Postfach 3309 • D-59282 Oelde Telefon (0 25 22) 76-0  
 Zum Sundern 13-21 • Germany Telefax (0 25 22) 76-444  
 eMail: mail@hammelmann.de • Internet: www.hammelmann.com



- Rod force: 39 kN
- Stroke: 30 mm
- Mean piston speed at n<sub>2</sub>  
 625 r.p.m. = 0,63 m/sec  
 750 r.p.m. = 0,75 m/sec  
 900 r.p.m. = 0,90 m/sec

Typical high pressure pump units



- Stationary unit with diesel motor



- Stationary unit with electric motor



- Mobile electric unit with hose reel